



WEIGHT CHANGES

	Operating weight	Tipping load			
		Straight		Full turn	
Remove ROPS canopy	-1385 kg -3,055 lb	-1220 kg	-2,690 lb	-1180 kg	-2,600 lb
Remove steel cab	-430 kg -950 lb	-335 kg	-740 lb	-330 kg	-730 lb
Install additional counterweight	+1600 kg +3,530 lb	+3850 kg	+8,490 lb	+3400 kg	+7,500 lb



STANDARD EQUIPMENT

- 2-spool valve for boom and bucket controls
- Alternator, 90 A/24 V
- Air conditioner
- Automatic transmission F3 / R3
- Back-up alarm
- Back-up lamp
- Batteries, 160 Ah/12 V x 4
- Boom kick-out
- Bucket positioner
- Counterweight
- Directional signal
- Emergency brake
- Engine, Komatsu SAA12V140E-3 diesel
- Floormat
- Front working lights (2)
- Hard water area arrangement (corrosion resister)
- Head lights (2)
- Lift cylinders and bucket cylinder
- Radiator mask, lattice type
- Rear access stairs
- Rear defroster (electric)
- Rearview mirrors
- Rear window washer and wiper
- Rear working lights (2)
- Room mirror
- ROPS/FOPS canopy
- Seat belt
- Seat, suspension type with reclining
- Service brakes, wet disc type
- Side working lights (2)
- Standard boom
- Starting motor, 7.5 kW/24 V x 2
- Steel cab included front wiper, windshield washer and power window
- Steering wheel, tiltable
- Sun visor
- Tires (45/65-45-46PR L5 tubeless) and rims
- Water separator



OPTIONAL EQUIPMENT

- AJSS (advanced Joystick Steering System)
- AM/FM radio
- AM/FM stereo radio cassette
- Ashtray and cigarette lighter
- Automatic greasing
- Bucket corner teeth
- Bucket teeth (weld-on/tip type)
- Counterweight for high lift boom
- Emergency steering (SAE)
- Engine pre-lube system
- Fast fill fuel system
- Fenders
- Fire extinguisher
- Heater and defroster
- High lift boom
- Mesh chain
- Ordinary spare parts
- Power train guard
- Rear under view mirror
- Short boom
- Sweeper wing
- Tires (45/65-45-50PR L5 tubeless)
- Tires (45/65-R45 L5 tubeless)
- Tool kit
- Under view mirror
- Vandalism protection
- VHMS (Vehicle Health Monitoring System)
- Yellow rotating lamp

www.Komatsu.com

Printed in Japan 200703 IP.SIN (10)

KOMATSU®

CEN00186-01

Materials and specifications are subject to change without notice
KOMATSU is a trademark of Komatsu Ltd. Japan

KOMATSU®

WA800-3E0

FLYWHEEL HORSEPOWER
603 kW 808 HP @ 2000 rpm

BUCKET CAPACITY
10.0-14.0 m³ 13.1-18.3 yd³

WA 800



Photo may include optional equipment.

WHEEL LOADER

WALK-AROUND

FLYWHEEL HORSEPOWER
603 kW 808 HP @ 2000 rpm

BUCKET CAPACITY
10.0–14.0 m³ 13.1-18.3 yd³

High Productivity & Low Fuel Consumption

- High performance SAA12V140E-3 engine
- Low fuel consumption
- Dual-mode active working power select system
- Large dumping clearance

See pages 4 and 5.

Excellent Operator Environment

- Automatic transmission with ECMV
- Tilttable steering column
- “AJSS” (Advanced Joystick Steering System) (Optional)
- Roomy, quiet cab with power windows
- Low vibration & noise
- Pillar-less large cab with ROPS/FOPS canopy
- Comfortable operator’s seat

See pages 8 and 9.

Reliability

- Reliable Komatsu designed and manufactured components
- Sturdy main frame
- Engine pre-lube system (Optional)
- Maintenance-free, fully hydraulic, wet disc brakes

See page 6.

- Hydraulic hoses use flat face O-ring seals
- Cathion electrodeposition process is used to apply primer paint
- Powder coating process is used to apply main structure paint
- Sealed DT connectors for electrical connections



GALEO

Building on the technology and expertise Komatsu has accumulated since its establishment in 1921, GALEO presents customers worldwide with a strong, distinctive image of technological innovation and exceptional value. The GALEO brand will be employed for Komatsu’s full lineup of advanced construction and mining equipment. Designed with high productivity, operator comfort and environmental considerations in mind, the machines in this line reflect Komatsu’s commitment to contributing to the creation of a better world.

**Genuine Answer for Land
and Environment Optimization**

Harmony with Environment

- EPA Tier 2 emission certified
- Low fuel consumption

Easy Maintenance

- Simple checks
- “VHMS” (Vehicle Health Monitoring System) (Optional)
- Rear access stairs
- Auto greasing system (Optional)

See page 7.

Photo may include optional equipment.

HIGH PRODUCTIVITY AND LOW FUEL CONSUMPTION

High Performance SAA12V140E-3 Engine

Electronic Heavy Duty Common Rail fuel injection system provides optimum combustion of fuel. This system also provides fast throttle response to match the machine's powerful tractive effort and fast hydraulic response.

Net: 603 kW 808 HP

Low Emission Engine

This engine is EPA Tier 2 emission certified without sacrificing power or machine productivity.

Low Fuel Consumption

Low fuel consumption is achieved because of the low-noise, high-torque engine and the large-capacity torque converter with maximum efficiency in the low-speed range.

Durable Bucket

Komatsu buckets are manufactured using high-tensile strength steel with replaceable welded wear plates for extended bucket life. Additional strength has been added to the bucket bottom corners, side edges and spill guard ends for increased durability.

Bucket capacities
11.0m³ 14.4cu.yd

Dual-Mode Active Working System

The machine can be equipped with two mode active working system. This system provides the most efficient hydraulic flow for your operation. The active working switch has two modes: powerful loading or normal loading.

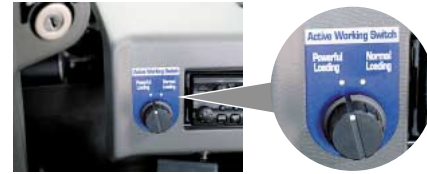

Dual modes switch

• Powerful loading mode:

Hydraulic flow towards the work equipment can be increased and reduced as and when required.

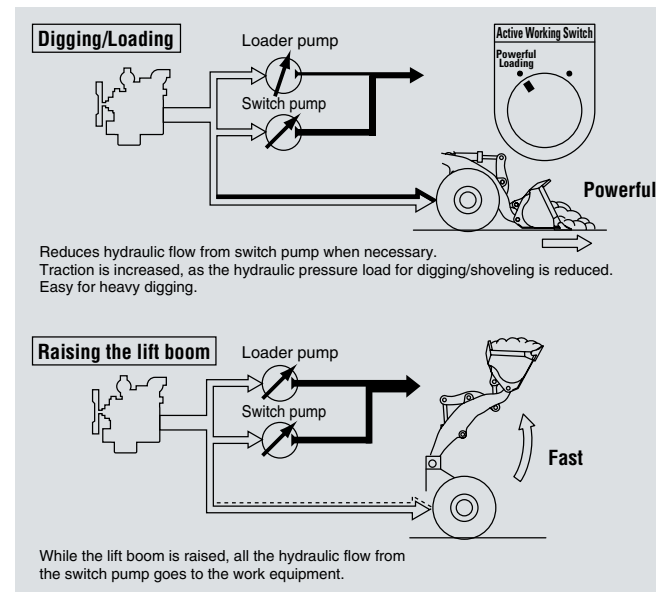

• Normal loading mode:

All hydraulic flow is transferred directly to the work equipment.

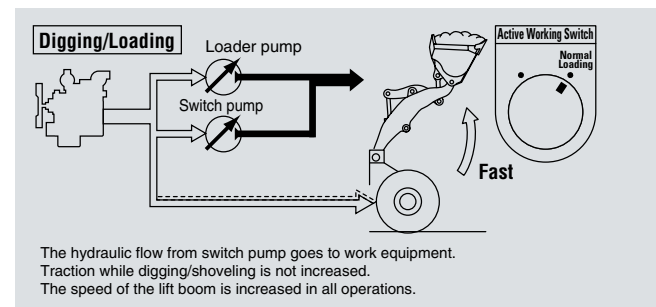

Large Dumping Clearance

The WA800-3 was designed with ample dumping clearance for dump truck matching.

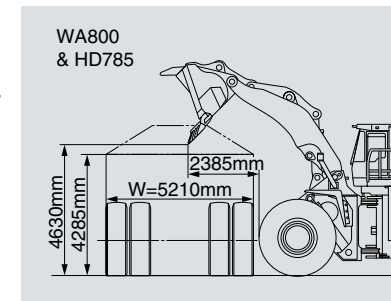

Excellent Stability

The WA800-3 has the widest tread in its class **3,350mm (11')** and a long **5,450mm (17'11")** wheelbase, for maximum machine stability.

Static tipping load

(with 45/65-45-46 PR (L-5) tires / bucket 11.0 m³ 14.4 yd³)

Straight: 61090 kg 134,680 lb

40° full turn: 53740 kg 118,480 lb

High Breakout Force

Komatsu wheel loaders have high-tensile steel Z-bar loader linkages for maximum rigidity and maximum breakout force. Sealed loader linkage pins extend greasing intervals.

Breakout force: 69000 kg 152,120 lb

11.0 m³ 14.4 yd³ Excavating bucket (spade nose) with tipteeth



INCREASED RELIABILITY

Komatsu Components

Komatsu manufactures the engine, torque converter, transmission, hydraulic units, electric parts, on this wheel loader. Komatsu loaders are manufactured with an integrated production system under a strict quality control system.

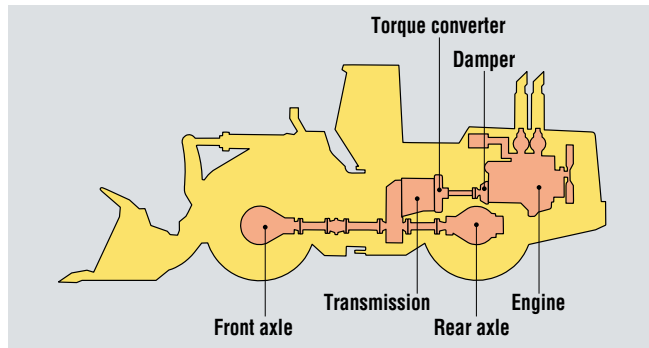

High-rigidity Frames and Loader Linkage

The front and rear frames and the loader linkage have more torsional rigidity to secure resistance against increased stress. Frame and loader linkage are designed to accommodate actual working loads, and simulated computer testing proves its strength.

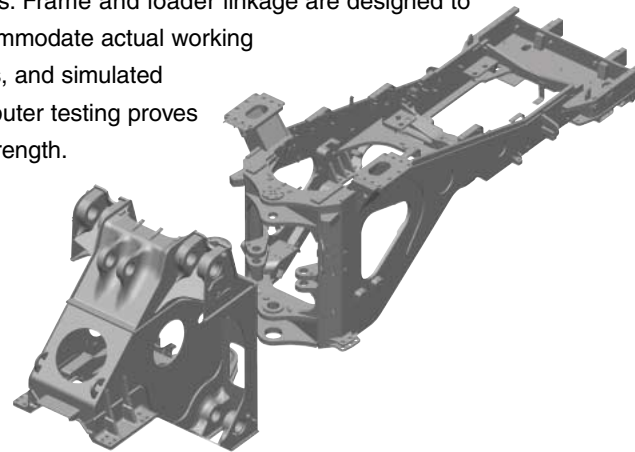

Engine pre-lube System (optional)

Durability of the engine is achieved by raising the engine oil pressure before starting the engine. When the operator turns the key, the pre-lubrication pump sends oil from the engine oil pan to the engine oil filter and raises the pressure of that oil to the set pressure. Then, the starting motor rotates to start the engine.

Maintenance-Free Braking System

Service brakes employ two hydraulically-actuated independent circuits which are adjustment-free, fully-sealed, wet disc units, preventing intrusion of dirt and dust. Since the brake system does not use air, it provides many features such as absence of condensation, dependable braking even in cold conditions, no need for drainage, and rust free piping. What's more, charging time after engine starting is drastically shortened and pedal depressing effort is reduced.

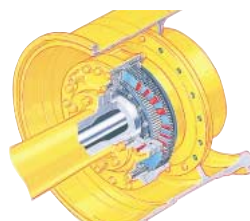

Flat Face-to-Face O-Ring Seals

Flat face-to-face O-ring seals are used to securely seal hydraulic hose connections and to prevent oil leakage. In addition, buffer rings are installed to the head side of the all-hydraulic cylinders to lower the load on the rod seals and maximize reliability.

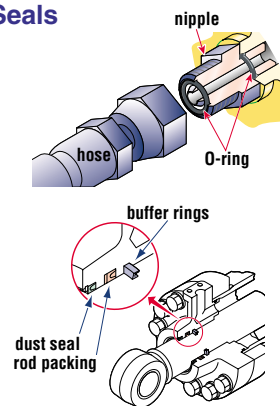

Cathion Electrodeposition Primer Paint/ Powder Coating Final Paint

Cathion electrodeposition paint is applied as a primer paint and powder coating is applied as topcoat to the exterior sheet metal parts. This process results in a durable paint finish, even in the most severe environments. Some external parts are made of plastic providing long life and high impact resistance.

Sealed DT Connectors

Main harnesses and controller connectors are equipped with sealed DT connectors providing high reliability, water resistance and dust resistance.



EASY MAINTENANCE



Photo may include optional equipment.

Simple Checks, Easy Maintenance

The main monitor and the maintenance monitor (EDIMOS II) are neatly arranged on the instrument panel for a quick, clear reading of machine functions at all times. The main monitor also has a diagnostic function.

Main monitor



Maintenance monitor



Large Side Door

Right side door is easy to open and provides accessibility for maintenance.



Fuel Tank Cap with Mud Cover and Large Tool Box

Fuel tank cap



Tool box



Rear Access Stairs

For the purpose of boarding and exiting machine, rear access stairs with handrail is provided. The step width, clearance, and the step angle have been designed for climbing both up and down. A step light provides light for night boarding.



Auto-Greasing System (optional)

The periodic lubrication points, except for drive shaft, are greased automatically according to a preset amount and interval. Quick-change grease canisters make replacement easy and clean.

VHMS (Vehicle Health Monitoring System) (optional)

VHMS is a management system for large equipment for use in mining, which enables detailed monitoring of fleet via satellite communications. Komatsu and distributors can analyze "vehicle health" and other operating conditions and provide the information to job site using the internet from a remote location on a near-real time basis.

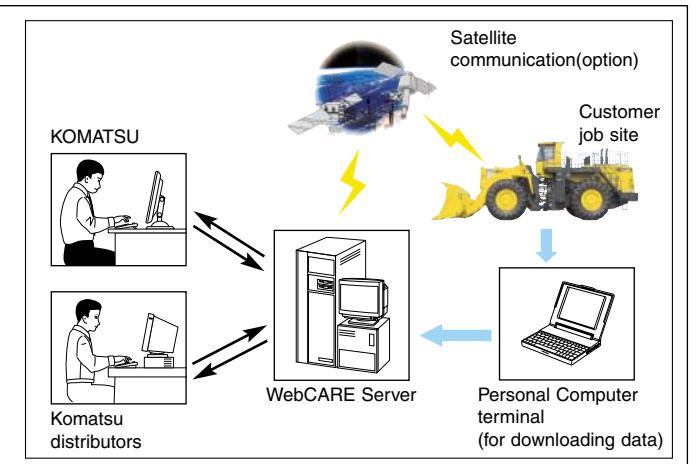

OPERATOR ENVIRONMENT

Easy Operation

Automatic Transmission with Electronically Controlled Modulation Valve (ECMV)

Automatic transmission with ECMV automatically selects the proper gear speed based on travel speed, engine speed, and other travel conditions. The ECMV system engages the clutch smoothly to prevent lags and shocks when shifting. This system provides efficient machine operation and a comfortable ride.

● **Kick-down switch:**

This valuable feature for increases productivity.

With the touch of a finger, the kick-down switch automatically downshifts

from second to first when

beginning the digging cycle. It automatically upshifts from first to second when the direction control lever is placed in reverse. This results in increased rim pull for better bucket penetration and reduced cycle times for higher productivity.

- **Hold switch:** Auto shift is selected and if the operator turns on this switch when the lever is at the 3rd gear speed position, the transmission is fixed to that gear speed.

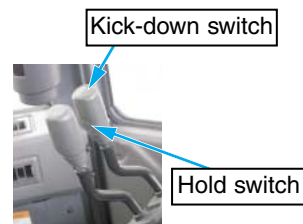
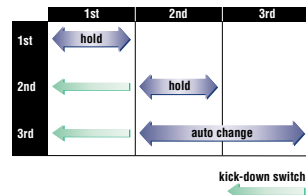

Electronically Controlled Transmission Lever

Easy shifting and directional changes with Komatsu two-lever electronic shifting. Change direction or shift gears without removing the shifting hand from the steering wheel. Solid state electronics and conveniently located direction and gear shift controls make this possible. Automatic shifts in ranges two through four keep production high and manual shifting at a minimum.



Steering Wheel Type



Tilttable Steering Column & One-Glance Monitors

The steering column can be easily tilt-adjusted to the most comfortable position with one lever.



Variable Transmission Cut-off System

The operator can set the transmission cut-off pressure desired for the left brake pedal using the switch located on the right-side control panel. The operator can improve the working performance by setting the cut-off pressure properly depending on working condition.

- High cut-off pressure for digging operations.
- Low cut-off pressure for truck-loading operations.



1:T/M cut-off ON/OFF switch
2:T/M cut-off set switch

Remote Boom Positioner

The highest and lowest position of the bucket can be set from the cab to match any truck body. Once the positioner is set, the bucket is smoothly stopped at desired position with no shock.



3:Remote boom positioner switch

AJSS (Advanced Joystick Steering System) (Optional)

AJSS is a feedback steering system which has been incorporated to allow steering and forward and reverse selection to be controlled by wrist and finger control.

With the feedback function, the machine steering angle is exactly the same angle as the lever tilt angle.

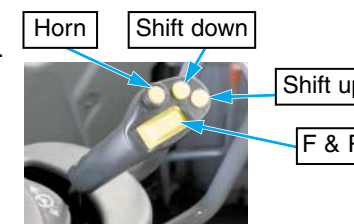

Comfortable Operation

Roomy, Quiet Cab With Power Windows

The cab is large, with a comfortably spacious interior and power windows. Also, a wide viewing angle is guaranteed because the cab is pillar-less. By adopting a high-capacity air conditioner, Komatsu ensures operator comfort, no matter the exterior conditions. Other features designed with operators in mind include a lunchbox storage space.



Lunchbox storage space

Low Vibration & Noise

The cab rests on Komatsu viscous damping mounts (rubber and silicon oil) to reduce vibration and noise. All hydraulic equipment is mounted on high-resistance rubber to further reduce vibration and noise.

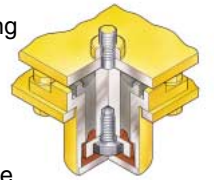

Pillar-less Large Cab with ROPS / FOPS Canopy

A wide pillar-less flat glass provides excellent front visibility. The wiper arm covers a large area to provide great visibility even on rainy days.



Rear heated glass provides clear view even in freezing or condensation conditions.



Comfortable Operator's Seat

The operator's seat has a reclining/air suspension design with headrest to support the operator comfortably during long operation. Also, it is easy to adjust seat height with air suspension.



SPECIFICATIONS



ENGINE

ModelKomatsu SAA12V140E-3
 TypeWater-cooled, 4-cycle
 AspirationTurbocharged, air-to-air aftercooled
 Number of cylinders12
 Bore x stroke140 mm x 165 mm 5.51" x 6.50"
 Piston displacement30.48 ltr 1860 in³
 Governorall-speed, electronic
 Flywheel horsepower
 SAE J1995Gross **636 kW** 853 HP
 ISO 9249/SAE J1349Net **603 kW** 808 HP
 Rated rpm2000 rpm
 Fan drive method for radiator coolingMechanical
 Fuel systemDirect injection
 Lubrication system:
 MethodGear pump, force-lubrication
 FilterFull-flow and bypass combined
 Air cleanerDry type with automatic dust ejector and pre-cleaner, cyclopac with vacuator



TRANSMISSION

Torque converter:
 Type3-element, single-stage, single-phase
 Transmission:
 TypeFull-powershift, planetary type
 Travel speed: **km/h** mph
 Measured with 45/65-45-46 tires

	1st	2nd	3rd
Forward	7.0 4.3	12.3 7.6	28.0 17.4
Reverse	7.1 4.4	12.4 7.7	28.3 17.6



AXLES AND FINAL DRIVES

Drive systemFour-wheel drive
 FrontFixed, full-floating
 RearCenter-pin support, full-floating,
 22° total oscillation
 Reduction gearSpiral bevel gear
 Differential gearStraight bevel gear
 Final reduction gearPlanetary gear, single reduction, oil bath



BRAKES

Service brakesHydraulically actuated,
 wet disc brakes actuate on four wheels
 Parking brakeDry disc brake
 Emergency brakeParking brake is commonly used



STEERING SYSTEM

TypeArticulated type, full-hydraulic power steering
 Steering angle40° each direction
 Minimum turning radius at
 the center of outside tire**9200 mm** 30'2"



HYDRAULIC SYSTEM

Steering system:
 Hydraulic pumpPiston pump
 Capacity**307 ltr/min** 81 U.S. gal/min at rated rpm
 Relief valve setting**31.4 MPa** 320 kgf/cm² 4,550 psi
 Hydraulic cylinders:
 TypeDouble-acting, piston type
 Number of cylinders2
 Bore x stroke**160 mm x 503 mm** 6.3" x 19.8"
 Loader control:
 Hydraulic pumpPiston pump
 Capacity**405 ltr/min** 107 U.S. gal/min at rated rpm
 Relief valve setting**31.4 MPa** 320 kgf/cm² 4,550 psi
 Hydraulic cylinders:
 TypeDouble-acting, piston type
 Number of cylinders—bore x stroke:
 Boom cylinder2- **260 mm x 1368 mm** 10.2" x 53.9"
 Bucket cylinder1- **300 mm x 906 mm** 11.8" x 35.7"
 Control valveSpool type
 Control positions:
 BoomRaise, hold, lower, and float
 BucketTilt-back, hold, and dump
 Hydraulic cycle time (rated load in bucket)
 Raise11.2 sec
 Dump2.0 sec
 Lower (Empty)4.8 sec



ROPS / FOPS & CAB

Structure complies with ISO 3471 and (Roll-Over Protective Structure) standards, as well as ISO 3449 FOPS (Falling Object Protective Structure) standards. The cab is mounted on rubber pads and is well insulated.



SERVICE REFILL CAPACITIES

Cooling system**337 ltr** 89.0 U.S. gal
 Fuel tank**1555 ltr** 410.8 U.S. gal
 Engine**130 ltr** 34.3 U.S. gal
 Hydraulic system**725 ltr** 191.5 U.S. gal
 Axle (each front and rear)**360 ltr** 95.1 U.S. gal
 Torque converter and transmission**140 ltr** 37.0 U.S. gal



BUCKET SELECTION GUIDE

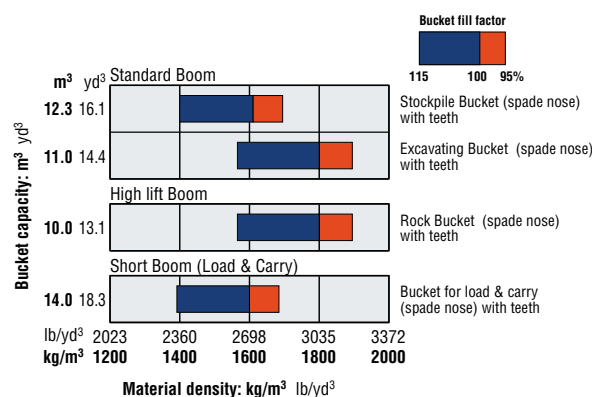

DIMENSIONS

Measured with 45/65-45-46PR(L-5) tires

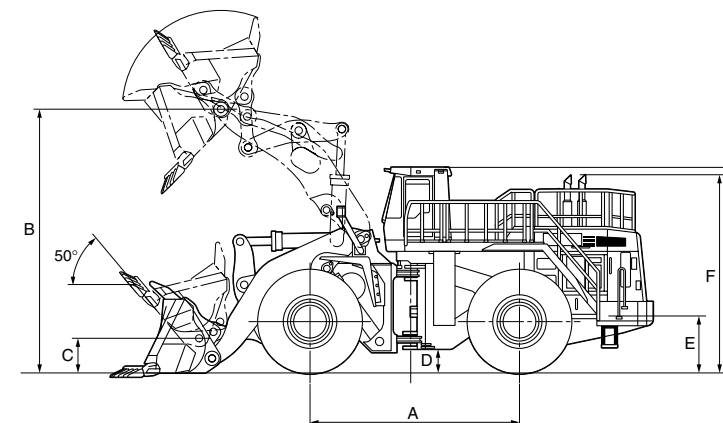

	Standard Boom	High lift Boom	Short Boom
Tread	3350 mm 11'		
Width over tires	4585 mm 15'1"		
A Wheelbase	5450 mm 17'11"		
B Hinge pin height, max. height	6785 mm 22'3"	7265 mm 23'10"	6140 mm 20'2"
C Hinge pin height, carry position	850 mm 2'9"		
D Ground clearance	550 mm 1'10"		
E Hitch height	1390 mm 4'7"		
F Overall height, top of the stack	5130 mm 16'10"		
G Overall height, ROPS cab	5275 mm 17'4"		

	Standard boom		High lift boom	Short boom
	Excavating Bucket	Stockpile Bucket	Rock Bucket	Load & Carry
	Spade nose Teeth	Spade nose Teeth	Spade nose Teeth	Spade nose Teeth
Bucket capacity: heaped	11.0 m³	12.3 m³	10.0 m³	14.0 m³
	14.4 yd ³	16.1 yd ³	13.1 yd ³	18.3 yd ³
struck	9.3 m³	10.4 m³	8.5 m³	11.5 m³
	12.2 yd ³	13.6 yd ³	11.1 yd ³	15.0 yd ³
Bucket width	4810 mm	4810 mm	4810 mm	5090 mm
	15'9"	15'9"	15'9"	16'8"
Bucket weight	11430 kg	12150 kg	10750 kg	12080 kg
	25,200 lb	26,790 lb	23,700 lb	26,630 lb
Dumping clearance, max. height and 45° dump angle	4630 mm	4252 mm	5210 mm	3820 mm
	15'2"	14'10"	17'1"	12'6"
Reach at max. height and 45° dump angle	2385 mm	2495 mm	2315 mm	2690 mm
	7'10"	8'2"	7'7"	8'10"
Reach at 2130 mm (7') clearance and 45° dump angle	3455 mm	3550 mm	3915 mm	3350 mm
	11'4"	11'8"	12'10"	11'0"
Reach with arm horizontal and bucket level	4360 mm	4510 mm	5010 mm	4550 mm
	14'4"	14'10"	16'5"	14'11"
Operating height (fully raised)	9300 mm	9430 mm	9625 mm	8740 mm
	30'6"	30'11"	31'7"	28'8"
Overall length	13960 mm	14110 mm	14695 mm	13685 mm
	45'10"	46'4"	48'3"	44'11"
Loader clearance circle (bucket at carry, outside corner of bucket)	21800 mm	21930 mm	22200 mm	22040 mm
	71'6"	71'11"	72'10"	72'4"
Digging depth: 0°	165 mm	165 mm	200 mm	200 mm
	6.5"	6.5"	7.9"	7.9"
10°	605 mm	630 mm	620 mm	670 mm
	2'0"	2'1"	2'0"	2'2"
Static tipping load: straight	61090 kg	60320 kg	58710 kg	68860 kg
	134,680 lb	132,980 lb	129,430 lb	151,810 lb
40° full turn	53740 kg	52970 kg	51640 kg	60660 kg
	118,480 lb	116,780 lb	113,850 lb	133,730 lb
Breakout force	676.7 kN	629.3 kN	703.5 kN	657.3 kN
	69000 kgf	64170 kgf	71790 kgf	67000 kgf
	152,120 lb	141,470 lb	158,270 lb	147,710 lb
Operating weight	101900 kg	102620 kg	103420 kg	104500 kg
	224,650 lb	226,240 lb	228,000 lb	230,380 lb

All dimensions, weights, and performance values based on SAE J732c and J742b standards.

Static tipping load and operating weight shown include lubricant, coolant, full fuel tank, ROPS canopy, air conditioner, bucket and operator. Machine stability and operating weight are affected by counterweight, or ballast, tire size, and other attachments.

Use either counterweight or ballast, not both. Apply the following weight changes to operating weight and static tipping load.