

# KOMATSU

## D475A-8R

### CRAWLER DOZER

# D475



Photos may include optional equipment.

#### HORSEPOWER

Gross:

Forward 697 kW 934 HP/2000 min<sup>-1</sup>

Reverse 777 kW 1040 HP/2000 min<sup>-1</sup>

Net:

Forward 664 kW 890 HP/2000 min<sup>-1</sup>

Reverse 722 kW 968 HP/2000 min<sup>-1</sup>

#### OPERATING WEIGHT

Semi-U Dozer: 112100 kg

U Dozer: 114600 kg

Super Dozer: 116800 kg

#### BLADE CAPACITY (ISO 9246)

Semi-U Dozer: 27.2 m<sup>3</sup>

U Dozer: 34.4 m<sup>3</sup>

Super Dozer: 45 m<sup>3</sup>

# WALK-AROUND

D475A-8R



## HORSEPOWER

Gross:  
Forward 697 kW 934 HP/2000 min<sup>-1</sup>  
Reverse 777 kW 1040 HP/2000 min<sup>-1</sup>  
Net:  
Forward 664 kW 890 HP/2000 min<sup>-1</sup>  
Reverse 722 kW 968 HP/2000 min<sup>-1</sup>

## OPERATING WEIGHT

Semi-U Dozer: 112100 kg  
U Dozer: 114600 kg  
Super Dozer: 116800 kg

## BLADE CAPACITY (ISO 9246)

Semi-U Dozer: 27.2 m<sup>3</sup>  
U Dozer: 34.4 m<sup>3</sup>  
Super Dozer: 45 m<sup>3</sup>



**OUTSTANDING PRODUCTIVITY & ENHANCED FRAME DURABILITY** contributes to reduction of the operation cost.  
**ENHANCED RIDE PERFORMANCE & WIDE AND EXCELLENT VISIBILITY** provides comfortable and efficient work for operator.



## Ecology & Economy Features

- Auto-deceleration function **NEW**
- Auto idle stop function **NEW**

## Performance Features

- 13% more power in reverse increases productivity. **NEW**
- Automatic transmission with lockup torque converter **NEW**
- Selectable working modes • Automatic/manual gearshift selectable modes

## Comfortable & Working Environmental Features

- Comfortable ride with equalizer bar shoulder pad **NEW**
- Comfortable ride with new cab damper mounts **NEW**
- Comfortable ride with new operator seat **NEW**
- Excellent visibility for blade/ripper work **NEW**
- Renewed steering and work equipment lever with optimized layout **NEW**
- Rear view monitor system **NEW**
- Electronic height adjuster for steering console **NEW**

## Safety Features

- Rear platform & guard rails **UPGRADE** • Heavy duty steps and large hand rails **UPGRADE**
- Secondary engine shutdown switch **NEW** • Operator Presence Sensing System **NEW**
- Seat belt caution indicator **NEW** • Power ladder (Optional) **NEW**
- Battery and starter isolator • Emergency engine stop switches (Optional)
- Tie-offs

## Reliability & Maintenance Features

- Robust main frame and track frame **NEW** • Modular long life powertrain design
- T-MEX\* **NEW** • Hinged type front mask and cooling fan support **NEW**
- One side greasing points for work equipment

\* T-MEX is a trademark of T.RAD Co., Ltd..

## Information & Communication Technology (ICT)

- Machine monitor with high resolution 7-inch color Liquid Crystal Display (LCD) unit **NEW**
- Energy Saving Operation **NEW**

## KOMATSU CARE & KOMTRAX PLUS

# ECOLOGY & ECONOMY FEATURES

## High Pressure Common Rail (HPCR) fuel injection system

The system is designed to achieve an optimal injection of high-pressure fuel by means of computerized control, thereby bringing close to complete combustion to reduce Particulate Matter (PM) emissions.

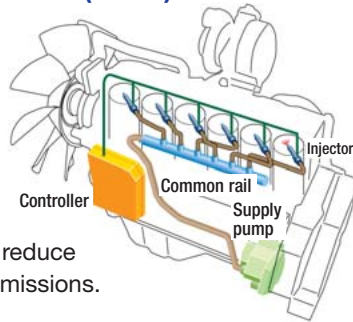

## Hydraulic Drive Radiator Cooling Fan

The engine cooling fan rotation speed is electronically controlled. The fan rotation speed depends on engine coolant, powertrain oil and hydraulic oil temperatures, the higher the temperature the higher the fan speed. This system increases fuel efficiency, reduces the operating noise levels and requires less horsepower than belt driven fan.

## Komatsu Auto Idle Stop

Komatsu auto idle stop helps reduce idle time and operating costs.

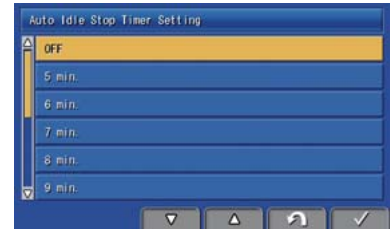

## Auto-deceleration function

The auto-decelerator automatically decreases the engine speed after selected period since the work equipment or travel lever return neutral.

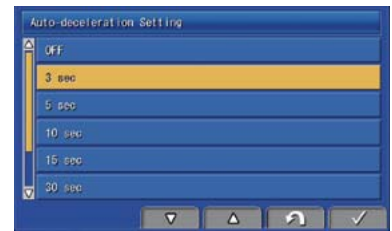

D475A-8R

# COMFORTABLE FEATURES

## Comfortable Operator Seat

New air suspension operator seat drastically improves vibration absorption performance. Furthermore, uniformed body pressure management increases contact area with body, which enhances hold performance and fatigue reduction for operator. This seat equips the lumbar support, tilting adjust function, electric heater and ventilator. It is easy to adjust to the various physical size of operator and also the electric heater makes it possible to work comfortably in the winter. And ventilator makes it possible too, in the summer.



Heater & ventilator

## Comfortable Ride with Equalizer Bar Shoulder Pad

Shoulder pad on the equalizer bar makes machine behavior smoother when driving over the obstacles. Additionally, reduced oscillation angle of equalizer bar suppresses machine rolling behavior. Those improvements provide more comfortable environment for operator in rough terrain operation.

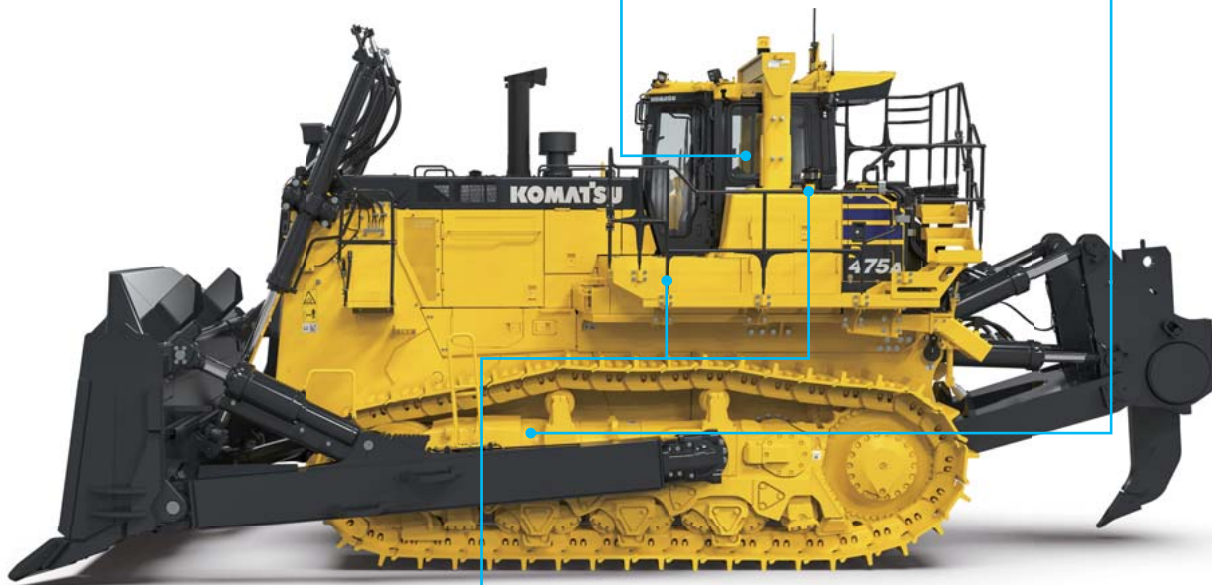

## Comfortable Ride with New Cab Damper Mounts

The D475A-8R's cab mount uses a new cab damper which provides excellent shock and vibration absorption capacity with its long stroke. These mounts soften shocks and vibration while traveling. Also, isolated cab from the machine body provides comfortable operation environment with less vibration and noise.

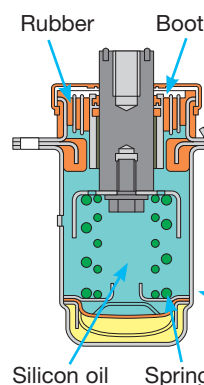

# PERFORMANCE FEATURES

## 13% More Power in Reverse

Increased engine output by 1.13 times when in reverse provides faster reverse climbing speed in downhill dozing. It leads to reduction of cycle time and increases the production drastically.

In downhill dozing (13°)

Production increased by **10%**

Compared with D475A-5E0

## Automatic Transmission with Lockup Torque Converter

A sharp reduction in fuel consumption and greater power train efficiency is achieved by the automatic gearshift transmission and lock up torque converter. The automatic gearshift transmission selects the optimal gear range depending on the working conditions and load placed on the machine. This means the machine is always operating at maximum efficiency. (Manual gearshift mode is selectable with a switch)

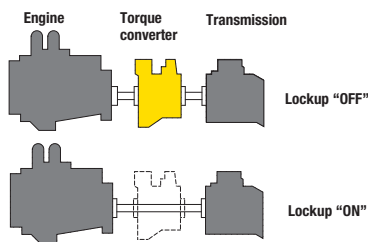

Fuel consumption reduced by **10%**

Compared with manual gearshift mode

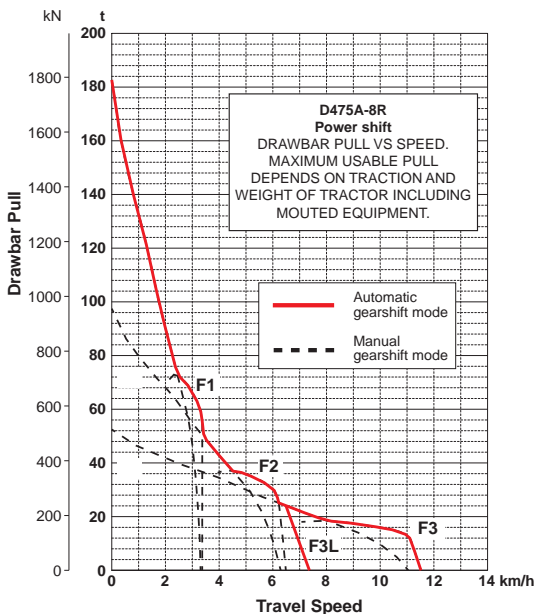

Lockup mechanism of torque converter is automatically actuated to transfer engine power directly to the transmission in usual dozing speed range. Locking up the torque converter eliminates loss of horsepower by 10%. Because the electronically controlled engine is extremely efficient, a decrease in fuel consumption is realized while also maintaining machine power.

## Selectable Working Modes

This mode can be set to either "P mode" for the maximum power or "E mode" for energy saving operation. Combined with the automatic gearshift mode or manual gearshift mode, the working mode allows the operator to select the optimum machine operating condition for the work at hand. (The mode can be switched during operation.)

**P mode** (Power mode): With P mode, the engine outputs its full power. Select this mode for the work requiring large production, heavy-load work, and uphill work.

**E mode** (Economy mode): Select for energy saving operation with restricted engine power output. Select for the work on a ground where the machine may cause shoe slip and frequent decelerator pedal operation is required. Select for the work not requiring large power such as downhill dozing, leveling, and light-load work.

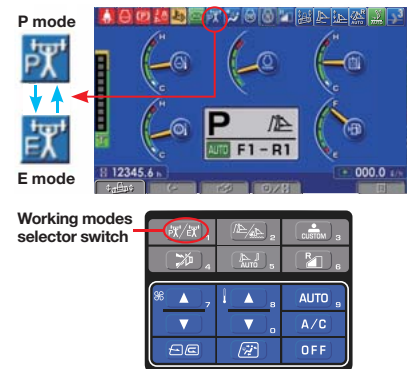

## Automatic/manual Gearshift Selectable Modes

Automatic or manual gearshift modes can be selected with ease to suit the work at hand by simply pressing the switch on the multi-monitor (Selection at neutral).

**Automatic gearshift mode:** The mode for general dozing. When a load is applied, the gear automatically shifts down, and when the load is off, it automatically shifts up to a set maximum gear speed. This mode economizes both fuel and production where the torque converter lockup mechanism is actuated according to load, automatically selecting the optimum gear speed.

**Manual gearshift mode:** The mode for dozing and ripping rough ground. When loaded, the gear automatically shifts down, but does not shift up when the load is off. The operator can specify whether the auto shift down function is enabled or disabled by operating the monitor.

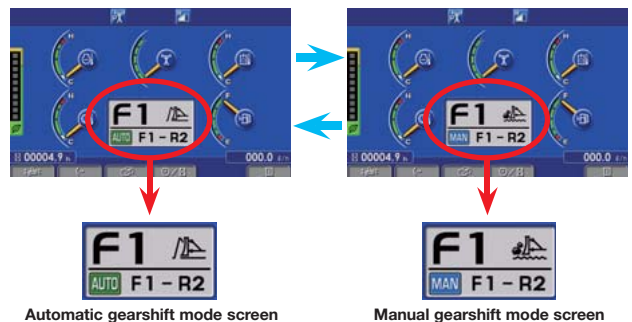

### Preset Travel Speed Selection Function

Preset travel speed enables the operator to select fore and aft travel speed among four preset patterns. When the gearshift pattern is set to either <F1-R1>, <F1-R2>, <F2-R2>, or <F2-R3L>, in automatic gearshift mode, the gear is automatically shifted. This function reduces gear shifting time during repeated round-trip operations.



Automatic gearshift mode	Manual gearshift mode	Shoe slip control mode (Optional)
<b>F1-R1 MODE</b> Press DOWN switch ↑ Press UP switch ↓	<b>F1-R1 MODE</b> Press DOWN switch ↑ Press UP switch ↓	<b>F1-R1 MODE</b> Press DOWN switch ↑ Press UP switch ↓
<b>F1-R2 MODE</b> Press DOWN switch ↑ Press UP switch ↓	<b>F1-R2 MODE</b> Press DOWN switch ↑ Press UP switch ↓	<b>F1-R2 MODE</b> Press DOWN switch ↑ Press UP switch ↓
<b>F2-R2 MODE</b> Press DOWN switch ↑ Press UP switch ↓	<b>F2-R2 MODE</b> Press DOWN switch ↑ Press UP switch ↓	
<b>F2-R3L MODE</b> Press DOWN switch ↑ Press UP switch ↓		

### Reverse Slow Mode

With the reverse slow mode, the engine speed is limited to reduce reverse travel speed in order to improve ride quality such as rough terrain operation.

### Electronic Smooth Steering Clutch/Brake Control

Sensors monitor machine operating conditions such as incline angle of slope and degree of load, controller selects the optimal modulation parameter automatically. The timing of engagement for clutch and brake is optimized to provide more smooth steering control.

### Track Shoe Slip Control Mode (Optional)

Optional track shoe slip control mode allows the operator not to constantly control engine power output with the decelerator pedal while ripping operation, substantially reducing operator fatigue. Maneuverability is improved because the operator is free to focus on monitoring to track shoe slippage. Repair costs are significantly lowered and undercarriage life is extended with the reduction in track shoe slippage. Additionally, this mode will contribute to lower fuel costs because the engine output is automatically controlled to optimum level for operation.



### High Penetration Force by Variable Giant Ripper

The variable giant ripper is a parallelogram single shank ripper ideal for ripping tough material. The ripping angle is variable, and the deeper reach of shank allows the operator to dig up a larger rock easily. Ripper shank height is adjustable in three stages by a hydraulically controlled pin puller.



# WORKING ENVIRONMENTAL FEATURES



## New Design Monocoque Cab

The D475A-8R has a tall and spacious cab with large glass windows for outstanding visibility. High rigidity structure greatly reduce noise and vibration for the operator and helps prevent dust entering into the cab. Optimum arrangement of fixed operator seat contributes to enhance the blade visibility drastically, and enables to design the optimized lever and pedal layout, which provides comfortable work environment for operator.

Optimized lever and pedal layout

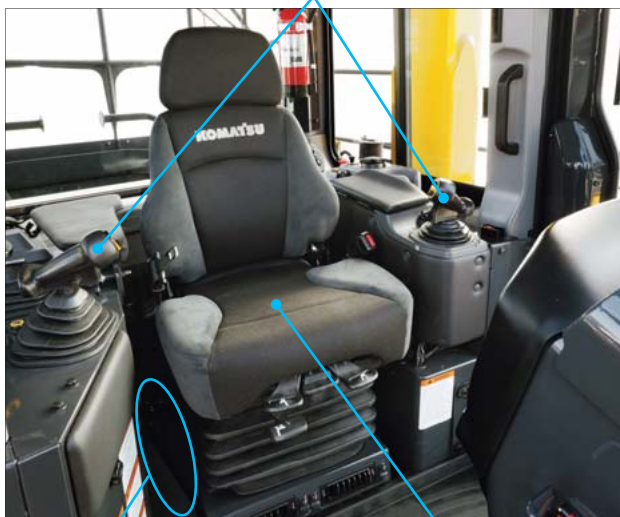

Enlarged foot space

New fixed operator seat layout

## Enlarged Visible Area of Ripper Shank

Thanks to the new ripper arm structure, the visible area of ripper shank is drastically enlarged. Operator is easy to rip the hard rock by locating the front edge of shank accurately.



## Rear View Monitor System

The operator can view the rear of the machine with a color monitor screen.





### Palm Command Control System (PCCS)

Ergonomically designed palm command travel joystick provides the operator with a relaxed posture and superb control improving operator comfort. Transmission gear shifting is simplified with push buttons.



### Finger Command Control System (FCCS) (Optional)

Newly developed Finger Command Control System allows operator to support his own body by hand firmly when traveling on uphill slope in reverse or on rough ground. Forward/Reverse can be selected by rocker switch and Right/Left steering control by finger-tip handle.

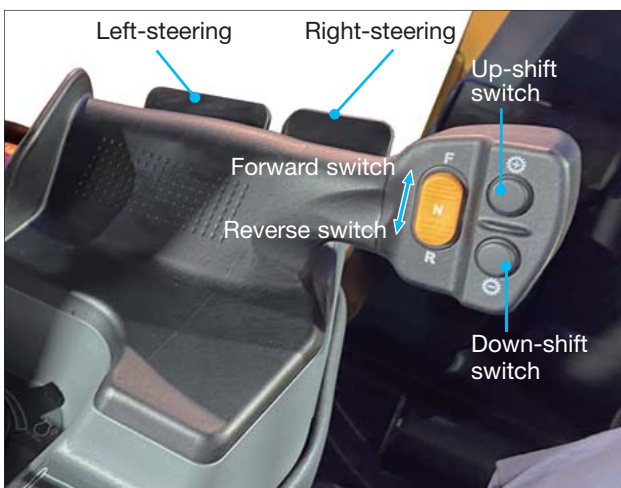

### Electronic Controlled Work Equipment Control Joystick

Electronically controlled work equipment control joystick allows operator to control blade and ripper quicker and more accurate than ever before. Blade fine control mode enables more smooth control for finish grading operation.



### Palm Command Ripper Control Joystick

Newly attached the one way ripper control joystick allows operator to hold his own body by hand while ripping.

Tilt in ⇔ Tilt back with toggle switch  
 Ripper lower ⇔ Ripper raise with one way lever



# WORKING ENVIRONMENTAL FEATURES

## Blade Auto-pitch

To reduce operator effort and increase operating efficiency, the new auto blade pitch mode sets dump positions while dozing and digging position while reversing, by one-touch operation with no additional lever movements. Moreover all blade operation (U dozer/Semi-U dozer/Super dozer) be consolidated regardless of blade type. The blade pitch control customization and adjustment can be set through the monitor.

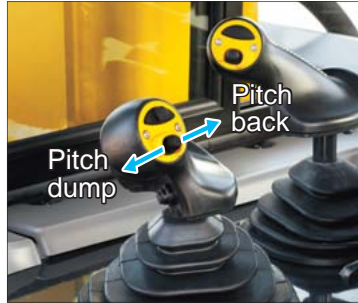

## Ripper Auto-return

The ripper control lever incorporates an auto-return function that will automatically raise the ripper, so the operator is less fatigued. The function activates automatically when travel lever is moved to reverse position.

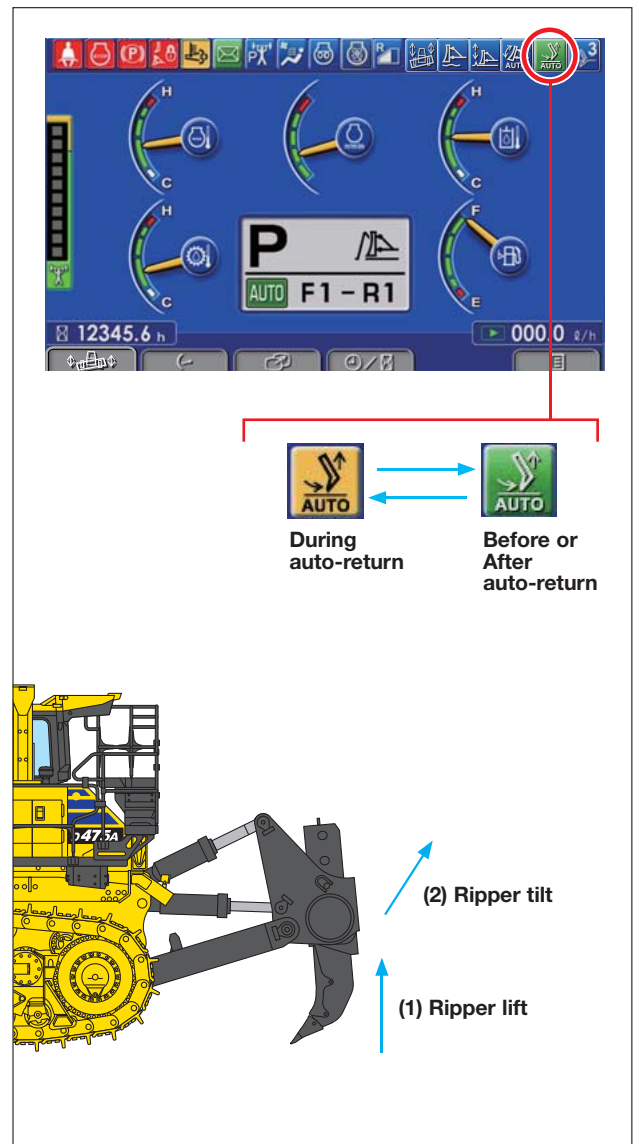
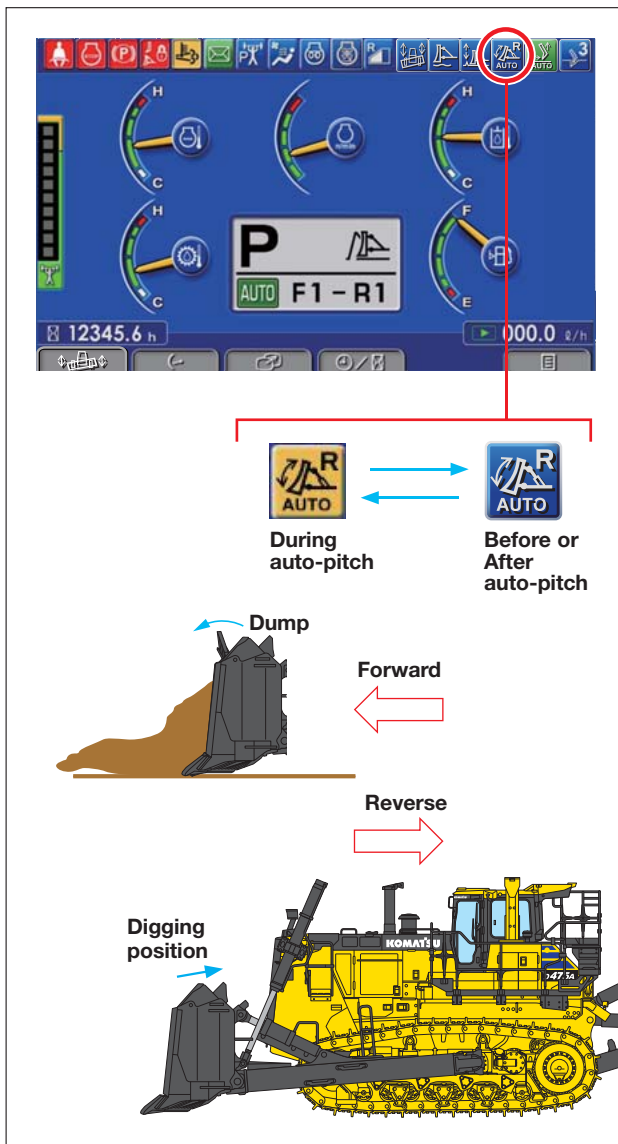
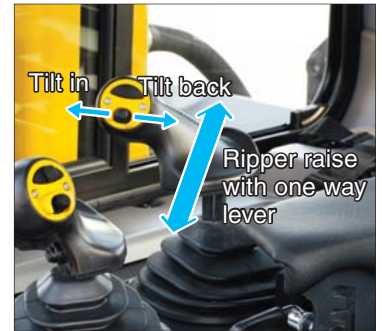



### Large Size Armrest

Wide armrest allows operator to put his elbow easily and support his own body during ripping work.



### Electronic Height Adjuster for Steering Console (Optional)

Height adjuster of steering console by electronic motor-driven provides easy height adjustment before starting operation.

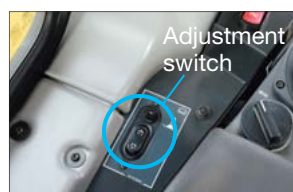

### Automatic Climate Control System

Automatic climate control system allows the operator to set the cab ambient temperature easily by the switch panel. Enhanced heating/cooling capacity and optimized wind outlet location keep the cab environment comfortable throughout the year.



### 12V Outlet Power Source and Aux Input Jack

Two 12V outlet power source and AUX input jack is equipped around left side of console.

- AUX input jack
- USB Port (Only for charge)
- 24V cigarette lighter
- 12V outlet
- 12V outlet



### Multifunction Audio(\*)

It has functions of AM/FM radio and AUX and Bluetooth® wireless technology enabled products can be connected.

(\*) Specification of audio depends on delivered area.

# SAFETY FEATURES

## One Side Platform with Hand Rails and Toe Boards

One side platform gives operator to access safely to rear maintenance points. Check and refilling of fuel and washer, cleaning of cab window glass and air conditioner condenser, cab lights, etc., can be safely performed.



## Heavy Duty Steps and Large Hand Rails

Strategically placed grab handles with non-slip steps aid operator getting on and off the machine.



## Secondary Engine Shutdown Switch

Secondary engine shutdown switch is newly equipped at the side of machine monitor. This is helpful when engine cannot shutdown normally via starting key switch.



## Operator Presence Sensing System

This feature locks out the power train and hydraulics under certain conditions to prevent unintentional movement when the operator is not in the seat.

## Seat Belt Caution Indicator

Reminds the operator to engage the seat belt.

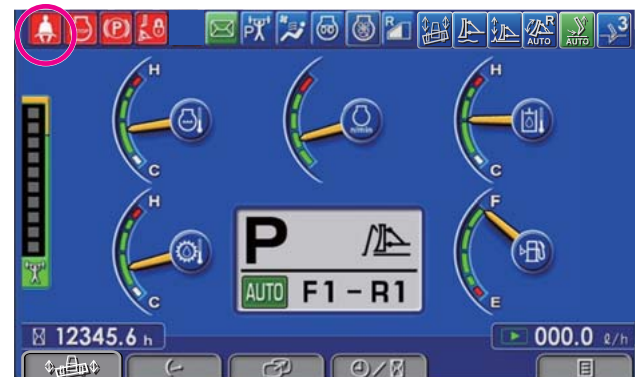

## Battery and Starter Isolator Box



Starter isolator

Battery isolator

Jump start receptacle

### Power Ladder (Optional)

Provides safer access and egress to and from the cabin.



### Tie-offs

Anchor points of Tie-off are installed. They are used to connect the safety belts of workers for maintenance and cleaning work.



### Emergency Engine Stop Switches (Optional)

In case you need to stop the engine immediately by using either of the two switches. One is installed in the cab, the other at the right rear of the machine.



# RELIABILITY & MAINTENANCE FEATURES

## Main Frame Strength

D475A-8R's main frame enhances its durability drastically with 118% stiffness increase compared with current machine.



## New Mono Blade Linkage

This structure provides less blade sway movement and extends maintenance interval of blade joint.



## T-MEX\*

T-MEX\* is equipped as standard cooling system. Easily and individually exchangeable tube and less clogging structure contribute to easy maintenance and less downtime. Damaged tube can be replaced individually instead of replacing whole assembly, which helps maintenance cost reduction or spare parts stock management.



\* T-MEX is a trademark of T.RAD Co., Ltd..

## Swing Fan

Easy access to the front-side of radiator core for cleaning by swing fan and foldable mask structure.



Double door mask  
Swing fan  
Easy to clean core

## Greasing Points

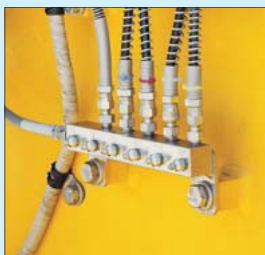

Blade lift cylinder yoke



Center pin and side pins both

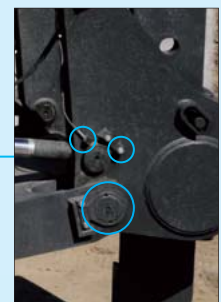

Ripper joints

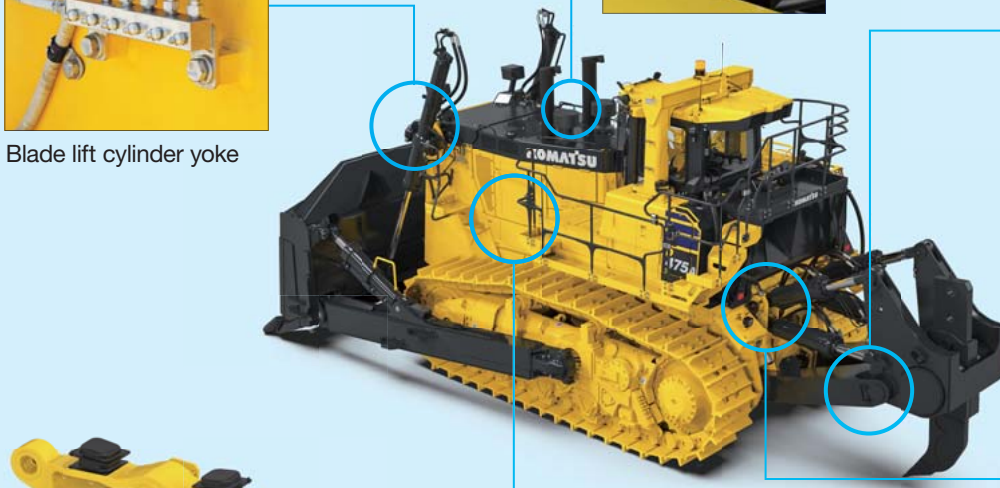

Equalizer bar pin (Access from right side)

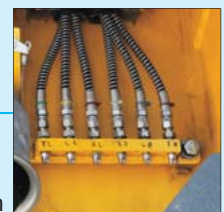

Ripper mount pin

**Maintenance Service Center (Optional)**

Couplings (Made by Wiggins) installed at the rear left of the machine enable quick drain and change of oil and coolant. The Fast Fuel Fill (Also by Wiggins) enables refueling from ground level. The service center eliminates the need to get on/off the machine and to remove/install covers to perform fluid maintenance.



Hydraulic oil  
Transmission oil  
Engine oil  
Radiator coolant  
Fast Fuel Fill

**Canister-type Breathers (Optional)**

Canister-type breathers are arranged inside the left exterior cover to facilitate check and cleaning of the breather of each component remotely.



Flywheel housing  
Damper case  
Powertrain case

**Concentrated Sampling Points (Optional)**

Concentrated sampling points are arranged inside the right side cab step cover to facilitate sampling of the oil and coolant from each component remotely.

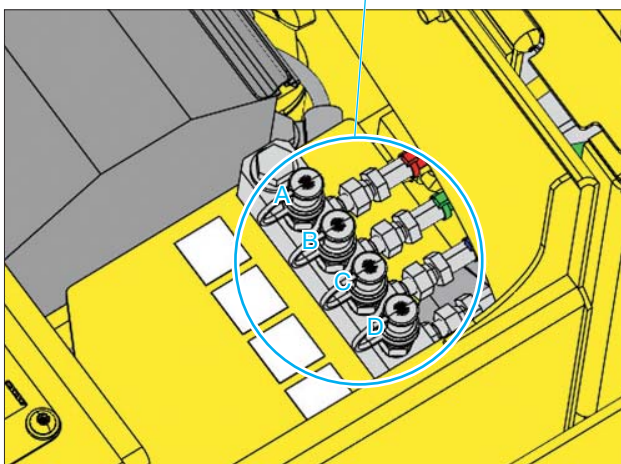
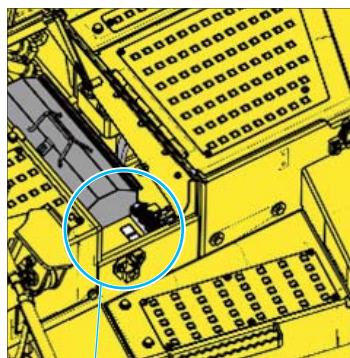

A: Transmission oil B: Radiator coolant C: Engine oil D: Hydraulic oil

## LARGE HIGH RESOLUTION LCD MONITOR



### Large Multi-lingual High Resolution LCD Monitor

A large user-friendly color monitor provides easy to understand information for the operator. Excellent screen visibility is achieved by use of a high resolution LCD monitor that can easily be read at various angles and lighting conditions. Simple and easy to operate switches. Plus function keys facilitate multi-function operations. The monitor displays data in 27 languages to globally support operators around the world.

### Multi-monitor with Troubleshooting Function to Minimize Down Time

Various meters, gauges and warning functions are centrally arranged on the multi-monitor. The monitor simplifies start-up inspection and promptly warns the operator with a lamp and buzzer if any abnormalities should occur. In addition, warning levels are indicated in 4 levels advise the operator of recommended actions. Replacement times for oil and filters are also indicated.





## Energy Saving Operation

### ECO guidance

In order to support to optimum operation, the following 5 guidance is displayed for fuel saving operation

- 1) Avoid excessive engine idling
- 2) Use economy mode to save fuel
- 3) Avoid hydraulic relief pressure
- 4) Avoid over load
- 5) Use automatic shift mode

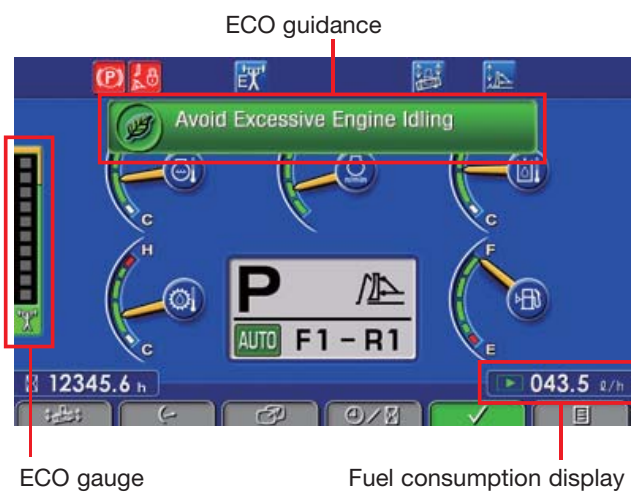

### ECO gauge

In order to help the operator to perform in an environmentally friendly way and minimize energy consumption, an easy-to-read "ECO gauge" is displayed on the left of the multi-monitor screen.

### Fuel consumption display

Average fuel consumption during the day is displayed on the right of the multi-monitor screen and updated every 10 seconds.

## Operation record, fuel consumption history, and ECO guidance record

The ECO guidance menu enables the operator to check the operation record, fuel consumption history and ECO guidance record by pushing the button on the monitor. The records can be used to reduce the overall fuel consumption.



Operation record



Fuel consumption record



ECO guidance record

# KOMTRAX Plus

## KOMTRAX Plus

**Assists Customer's Equipment Management and Contributes to Fuel Cost Cutting**

### Equipment Management Support

KOMTRAX Plus is a management system for large mining equipment, which enables detailed monitoring of the fleet via satellite and wireless LAN. Komatsu and distributors can analyze "machine health", other operating conditions and provide this information to the job site, using the Internet from a remote location, on a near-real time basis. As a result, customers receive timely machine maintenance, reduced maintenance expenses, downtime costs and avoid mechanical trouble.

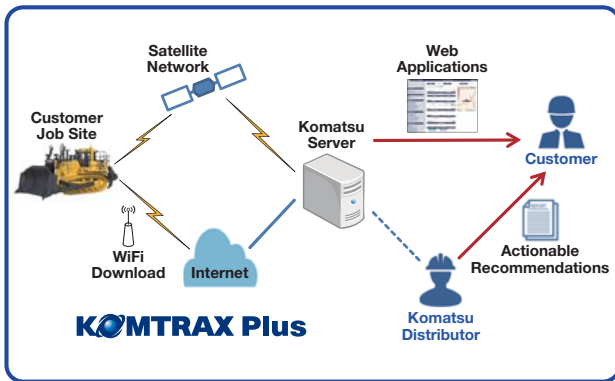

### Energy Saving Operation Support Report

KOMTRAX Plus provides various useful information which includes the energy-saving operation support report based on the operating information of your machine such as fuel consumption and idle time.

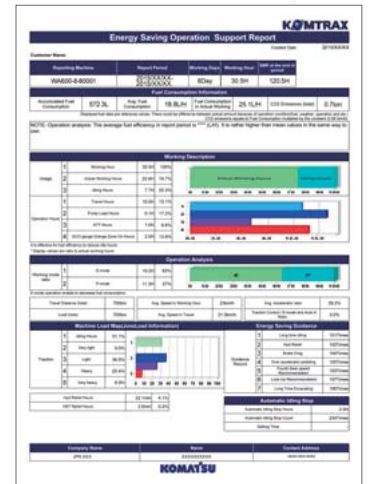

#### Working Status

- SMR
- Working Hours
- Idling %
- Fuel

#### Caution Record

- Caution occurrence time and location record per machine

#### Machine Location on Google Maps

- Searching driving route
- Link to Google Maps app

#### Tracking no usage/no communication machine

- List of machines not being used/not communicating for a day, a week, or a month



D475A-8R

# SUPER DOZER SPEC.

Super Dozer blade is appropriate for larger production, with specialized shape, capacity and control function. To achieve the best efficiency for dig, carry, or dump operation, it has wider range of pitch-angle. The operator can easily control the blade pitch with auto-pitch function.

## Production

increased by **15%**  
 (vs. U Dozer (Based on KOMATSU test method))



Photo may include optional equipment.

Super dozer is suitable for particular condition or applications, such as reclamation, leveling, or overburden dozing of loose material, while semi-U dozer is suitable for hard or rocky material digging or side cut application. Please consult your distributor about the suitable spec for your application.

Automatic repositioning and full dump positioning can be set easily by blade auto-pitch. Configuration of this function can be done with "work equipment automation switch" and "customize switch".

### Pitch angle control

Super dozer has wider range of blade pitch. Especially during the carry process, the blade gets flat, so that it can hold larger volume over the blade. This material reduces the volume in front of the blade to save the resistance and pushes the blade downward, which causes equal ground pressure and saves machine shoe slip.

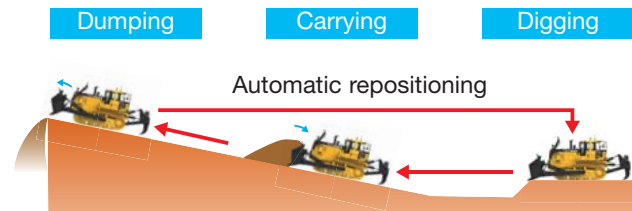

Super Dozer

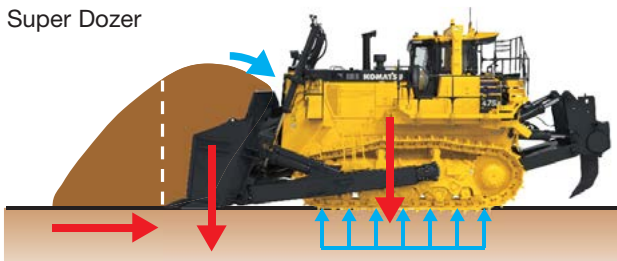

Semi-U/U Dozer

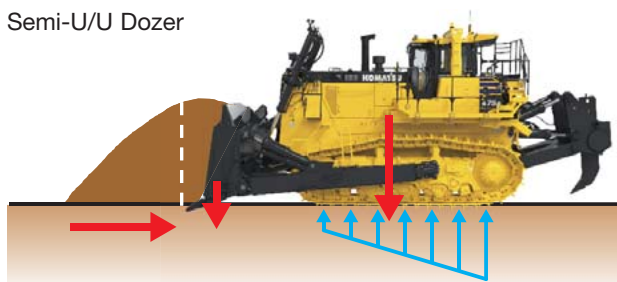

Monitor switch



Auto-pitch pilot lamp







**DIMENSIONS**

Semi-U Dozer	
A	2770 mm
B	5430 mm
C	4710 mm
D	2690 mm
E	4525 mm
F	11300 mm
G	3430 mm
H	1210 mm <sup>*1</sup>
I	1845 mm <sup>*2</sup>
J	4795 mm

\*1 Maximum lift above ground  
\*2 Maximum drop below ground

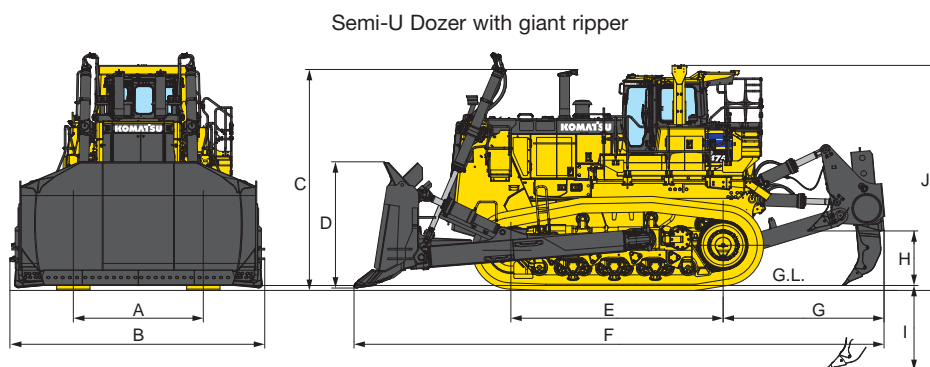

Ground clearance: 615 mm

U Dozer	
A	2770 mm
B	6205 mm
C	4710 mm
D	2610 mm
E	4525 mm
F	11800 mm
G	3430 mm
H	1210 mm <sup>*1</sup>
I	1845 mm <sup>*2</sup>
J	4795 mm

\*1 Maximum lift above ground  
\*2 Maximum drop below ground

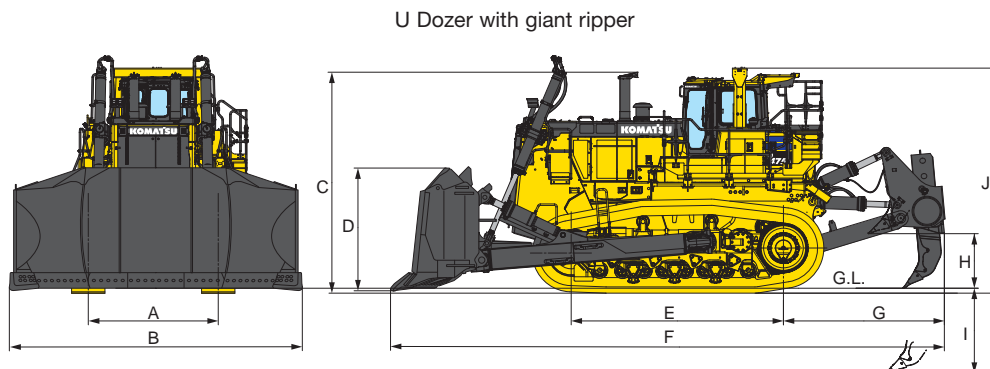

Ground clearance: 615 mm

Super Dozer	
A	2770 mm
B	6465 mm
C	4710 mm
D	2874 mm
E	4525 mm
F	11580 mm
G	3430 mm
H	850 mm <sup>*1</sup>
I	1700 mm <sup>*2</sup>
J	1000 mm
K	4795 mm

\*1 Maximum lift above ground  
\*2 Maximum drop below ground

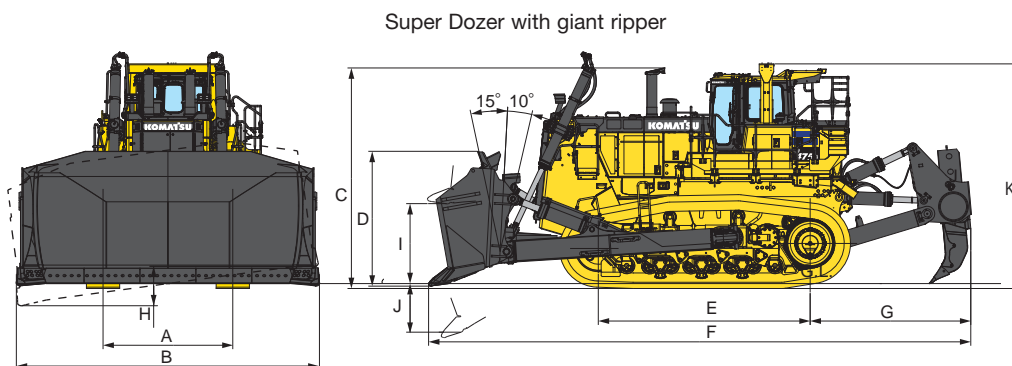

Ground clearance: 655 mm



**OPERATING WEIGHT**

Tractor weight

- Shoe 710 mm . . . . .86600 kg  
Including rated capacity of lubricant, coolant, full fuel tank, operator, and standard equipment.
- Shoe 810 mm . . . . .87500 kg  
Including rated capacity of lubricant, coolant, full fuel tank, operator, and standard equipment.

Operating weight

- Semi-U Dozer . . . . .112100 kg  
Including Semi-U dual tilt dozer, giant ripper, cab, ROPS (ISO 3471), operator, standard equipment, rated capacity of lubricant, coolant, and full fuel tank. Shoe 710 mm.
- U Dozer . . . . .114600 kg  
Including U dual tilt dozer, giant ripper, cab, ROPS (ISO 3471), operator, standard equipment, rated capacity of lubricant, coolant, and full fuel tank. Shoe 810 mm.
- Super Dozer . . . . .116800 kg  
Including Super Dozer, giant ripper, cab, ROPS (ISO 3471), operator, standard equipment, rated capacity of lubricant, coolant, and full fuel tank. Shoe 810 mm.
- Ground pressure
- Semi-U Dozer . . . . .171 kPa 1.74 kgf/cm<sup>2</sup>
- U Dozer . . . . .153 kPa 1.56 kgf/cm<sup>2</sup>
- Super Dozer . . . . .156 kPa 1.59 kgf/cm<sup>2</sup>



## HYDRAULIC SYSTEM

### Hydraulic control unit:

Closed-center load sensing system (CLSS) designed for precise and responsive control, and for efficient simultaneous operation.

### Hydraulic control unit:

All spool control valves externally mounted beside the hydraulic tank. Variable piston pump with capacity (Discharge flow) of 541 L/min for implement at rated engine rpm.

Relief valve setting . . . . .for implement 27.5 MPa 280 kgf/cm<sup>2</sup>

### Control valves:

Spool control valve for Semi-U tilt dozer, U tilt dozer and Super Dozer.

Positions: Blade lift. . . . . Raise, hold, lower, and float  
Blade tilt. . . . . Right, hold, and left

Additional control valve required for variable digging angle multi-shank ripper and giant ripper.

Positions: Ripper lift. . . . . Raise, hold, and lower  
Ripper tilt . . . . . Increase, hold, and decrease

Hydraulic cylinders . . . . . Double-acting, piston

	Number of Cylinders	Bore
<b>Blade Lift</b>	2	180 mm
<b>Blade Tilt (Dual tilt)</b>	2	250 mm
<b>Ripper Lift</b>	2	225 mm
<b>Ripper Tilt</b>	2	225 mm

### Hydraulic oil capacity (Refill):

Semi-U dozer or U dozer . . . . . 190 L

### Ripper equipment (Additional volume):

Giant ripper. . . . . 130 L

Multi-shank ripper (Variable). . . . . 130 L



## DOZER EQUIPMENT

Blade capacities are based on the ISO recommended practice 9246.

	Overall Length with Dozer	Blade Capacity (ISO 9246)	Blade Length x Height	Maximum Lift above Ground	Maximum Drop below Ground	Maximum Tilt Adjustment	Weight		Ground Pressure*
							Dozer Equipment	Hydraulic Oil	
<b>Dual Tilt Semi-U Dozer</b>	8900 mm	27.2 m <sup>3</sup>	5265 mm x 2690 mm	1650 mm	900 mm	1145 mm	18300 kg	109 kg	171 kPa 1.74 kgf/cm <sup>2</sup>
<b>Dual Tilt U Dozer</b>	9400 mm	34.4 m <sup>3</sup>	6205 mm x 2610 mm	1650 mm	900 mm	1350 mm	19900 kg	109 kg	153 kPa 1.56 kgf/cm <sup>2</sup>
<b>Super Dozer</b>	9175 mm	45 m <sup>3</sup>	6465 mm x 2874 mm	1700 mm	1000 mm	850 mm	22100 kg	132 kg	156 kPa 1.59 kgf/cm <sup>2</sup>

\*Ground pressure shows tractor with cab, ROPS (ISO 3471), variable giant ripper, standard equipment and applicable blade. Shoe 710 mm (Semi-U Dozer) and 810 mm (U Dozer/Super Dozer).



**STANDARD EQUIPMENT FOR BASE MACHINE**

- Air conditioner with heater and defroster
- Alternator, 24 V/140 A
- Back-up alarm
- Blower cooling fan
- Color monitor
- Decelerator pedal
- Double wiper for cab door
- Dry-type air cleaner with dust evacuator and dust indicator
- Dual tilt dozer
- Eight-roller track frames
- Electrical dust indicator
- Final drive case wear guard
- High mount head lights
- Hinged front mask
- Hinged fan support
- Hinged underguards with front pull hook
- Horn, warning
- Hydraulics for dozer
- Hydraulic track adjusters
- KOMTRAX Plus with Iridium
- LED light
  - Lighting system (including six front and two rear lights)
- Lockup torque converter
- Lunch box holder
- Maintenance-free batteries, 4 x 12 V /160 Ah\*
  - \*5 hour rate capacity
- Mirror, rearview
- Multifunction audio
- PCCS lever steering control
- Perforated side covers
- Platform with hand rails and toe boards
- Radiator reserve tank
- Rain cap
- Rear view monitor system
- Seat
  - Air suspension seat, fabric, low back rest, head rest, heater and ventilator
- Seat belt
- Segmented sprockets
- Shoes, 710 mm extreme service, single-grouser
- Starting motors, 2 x 24 V/7.5 kW
- TORQFLOW transmissions
- Track roller guards
- Uninterrupted power source for 3rd party system
- Vandalism protection kit (Cover locks)
- Wet steering clutches



**OPTIONAL EQUIPMENT**

- Extreme service shoes
  - 810 mm
  - 910 mm
- Fast fuel fill system
- Finger command control system
- Fire extinguisher
- Hydraulics for ripper
- Inspection light
- Light for ripper point
- Spare parts for first service
- Strengthened Semi-U blade
- Strengthened U blade
- Strengthened super dozer
- Tool kit
- Track shoe slip control system

**ROPS\***

Weight . . . . . 741 kg  
 Width . . . . . 2098 mm  
 Height

Compartment floor to ceiling . 1910 mm  
 \*Meets ISO 3471 standards.

**Multi-shank ripper**

Hydraulically controlled parallelogram ripper with three shanks. Ripping angle is steplessly adjustable.

Weight (Including hydraulic control unit and oil) . . . . . 9720 kg  
 Beam length . . . . . 3085 mm  
 Maximum lift above ground . . . 1210 mm  
 Maximum digging depth . . . . . 1240 mm

**Variable giant ripper**

Variable, parallelogram single-shank ripper ideal for ripping up tough material. Ripping angle is variable. Ripping depth is adjustable in four stages by a hydraulically controlled pin puller.

Weight (Including hydraulic control unit and oil) . . . . . 7210 kg  
 Beam length . . . . . 1500 mm  
 Maximum lift above ground . . . 1210 mm  
 Maximum digging depth . . . . . 1845 mm

**Counter weight**

Weight . . . . . 7420 kg

**Mining specifications**

- Access lights
- Battery/starter isolators
- Canister-type breather
- Concentrated sampling points
- Evacuation service center
- Group lube for blade or ripper
- Manual emergency engine shutdown switches
- Power ladder
- Provision for power ladder
- Working light for the engine bay

- The Bluetooth® word mark and logos are registered trademarks owned by Bluetooth SIG, Inc. and any use of such marks by KOMATSU Group is under license. Other trademarks and trade names are those of their respective owners.
- Up to 20% blended biodiesel fuel and paraffine fuel can be used. Please consult your Komatsu distributor for detail.

<https://www.komatsu.jp/en>

Printed in Japan 202212 IP.As

The image shows the Komatsu logo, which consists of the word "KOMATSU" in a bold, blue, sans-serif font. The logo is positioned inside a thin black rectangular border.