

# KOMATSU

## P&H

### 4800XPC

Electric Mining Shovel  
Product Overview





**Who we are:**

Since 1921, Komatsu has stood for unrivaled quality and reliability. Our enduring global success stems from the principles of our founder, Meitaro Takeuchi, who envisioned a sustainable future built through globalization, quality first, technology innovation and talent development. These defining principles, along with an emphasis on safety and compliance, remain part of our Komatsu DNA. With each brand and company added to the Komatsu family, we expand our capabilities, leveraging our global teams to push beyond what can be done and create what can be imagined. We believe partnering directly with our stakeholders and being in the workplace (gemba) is the best way to gain insight into their challenges, win their trust and develop cutting-edge solutions.

**What we do:**

Komatsu is an indispensable partner to the mining, forestry, industrial and construction industries that maximizes value for customers through innovative solutions. With a full line of products supported by our advanced IoT technologies and global service network, we help customers safely and sustainably optimize their operations. Our **Komatsu, P&H, Joy** and **Montabert** equipment and services are used to extract fundamental minerals and develop modern infrastructure.



**Hour after productive hour,  
P&H shovels were inspired by you**

You manage a large mining operation focused on the most efficient extraction of valuable commodities like copper, coal, iron ore, petroleum or gold.

Your mine plan changes daily or perhaps hourly as complex factors interplay.

You require highly reliable and productive equipment to help ensure your ability to obtain sustained throughput rates – and optimized production costs.

You have invested in the very best available mix of capital equipment – including your P&H electric shovels – to help realize your operations management objectives.

You helped inspire us to design, build and support these exceptionally tough, smart loading machines. Komatsu Mining has transformed your ideas and your insights into best-in-class P&H electric mining shovels for the cost and safety-focused mining industry.



**4800XPC: breakthrough design**

Driven by the need to meet increasing production demands, mine owners have introduced ultra-class haul trucks to their operations. Meeting those production goals has remained a challenge due to the lack of an electric mining shovel on the market that can efficiently load large 360 mt (400 st) trucks – until now.

Komatsu Mining has been the electric mining shovel market share leader and a preferred equipment supplier to the world's toughest mining environments for over 100 years. We have taken that mining application knowledge along with our engineering expertise and applied it to the development of a breakthrough design.

Built upon the proven performance of the P&H 4100XPC AC, the 4800XPC leverages new Adaptive Controls technology (patents pending) with optimized machine structures to enable its larger payload and increase efficiencies. The 4800XPC is designed to deliver:

- 122 mt (135 st) payload
- 3 pass load 360 mt (400 st) ultra-class haul trucks
- Up to 20% production increase over 4100XPC AC
- Up to a 10% decrease in cost per tonne



### Complete structural optimization

The P&H 4800XPC features robust machine structures and systems to improve **performance, maintainability** and **reliability**: a powerful combination designed to deliver **ultra-class productivity**



- Dipper**
- Higher payload to weight ratio
  - Improved fill factor, reduced wear and reduced dig energy per tonne
  - Improved latch system for reduced maintenance and improved performance



- New bail and equalizer**
- Provides for proper combination of digging height, cutting force, dumping height and rope life



- Direct drive crowd with integral fleeting sheave**
- Reduces maintenance costs
  - Helps to eliminate boom jacking



- Modular counterweight and boarding stairs**
- Enhances safety and access
  - Faster assembly/disassembly



- Enhanced ring gear**
- Resists fatigue
  - Accommodates increased payload



- Optimized boom design with stabilized handle geometry**
- Dipper maneuverability
  - Improved maintenance access

### Advanced technology

**Adaptive Controls**

A series of control functions that optimize shovel power usage in different phases of the dig cycle, these features have been field tested to demonstrate improved shovel performance while lessening the effect of operating impacts on the machine:



- Smart control and application of power
- Improves shovel production without sacrificing life
- Reduces boom jacking



- Smart Crowd**
- Improves bank penetration
  - Improves operator efficiency
  - Reduces boom jacking



- Opti Toe**
- Improves cutting force and productivity
  - "Rewards" operators for staying in the optimal dig envelope



- Smart Retract**
- Smoother disengagement from the bank
  - Reduces structural loading



- Active Load Compensation**
- Optimizes machine torques and speeds
  - Active during excessive payload conditions



- Extended Reach**
- Improves dump reach

# 4800XPC Electric Mining Shovel

## General Specifications

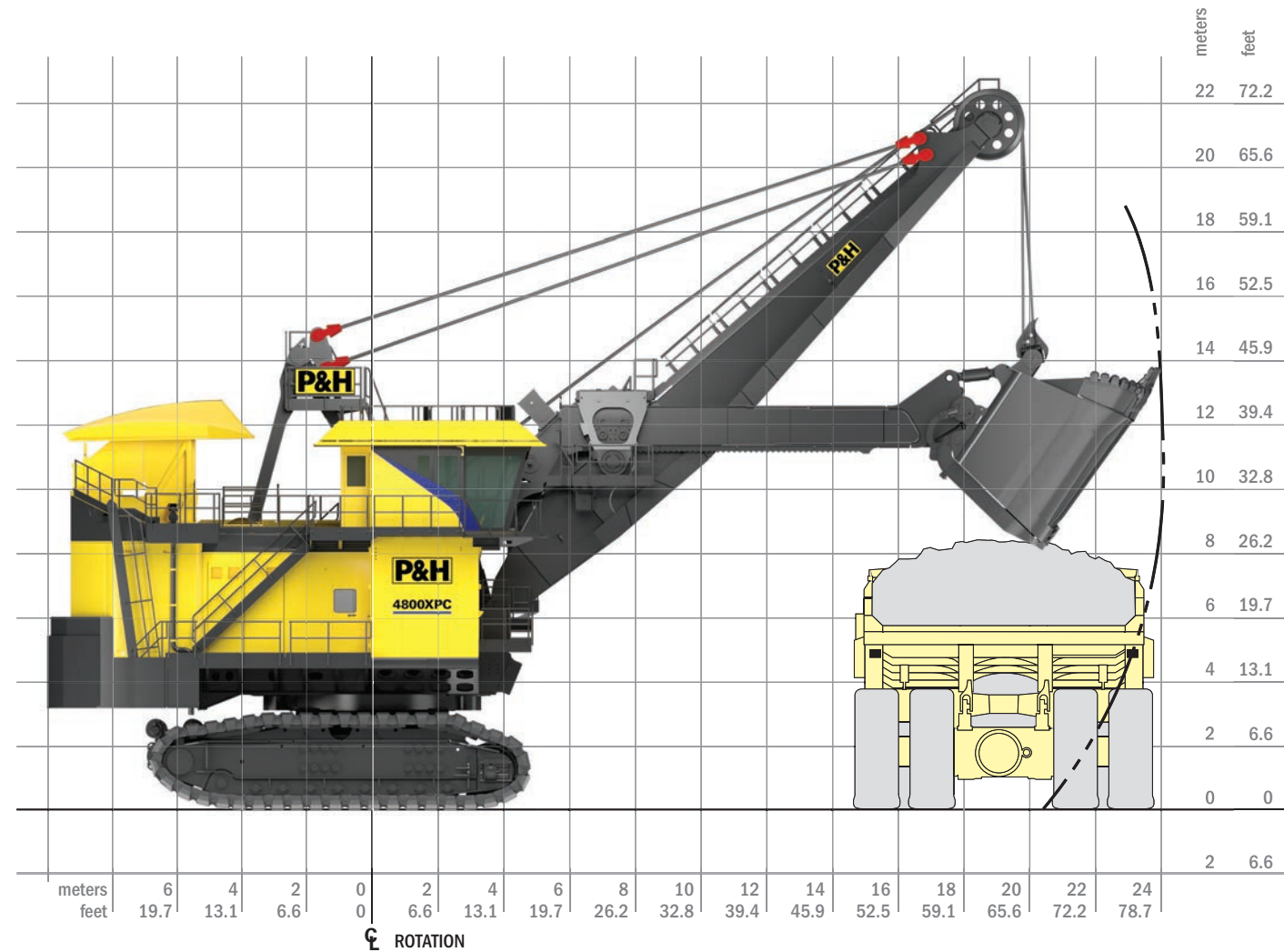

Working ranges		
Height of cut	18.9 m	62 ft. 2 in.
Radius of cut	24.0 m	78 ft. 7 in.
Max dump reach (furthest distance to center of truck)	19.4 m	63 ft. 6 in.
Dumping height* (door open)	10.8 m	35 ft. 7 in.
Floor level radius	16.2 m	53 ft. 3 in.
Tail swing radius	9.9 m	32 ft. 7 in.
Operator eye level	10.1 m	33 ft. 1 in.

Capacity		
Nominal payload*	122.5 mt	135 st
Nominal dipper capacity		
SAE struck	65.7-70.3 m <sup>3</sup>	86-92 yd <sup>3</sup>
SAE 2:1	72.5-77.6 m <sup>3</sup>	92.7-99.1 yd <sup>3</sup>
Rated suspended load	223.6 mt	246.5 st
Optimum truck size (360 mt (400 st) truck shown)	360 mt	400 st

\*Payload and dipper capacity are dependent on many factors. Contact Komatsu Mining for an analysis of your specific application.

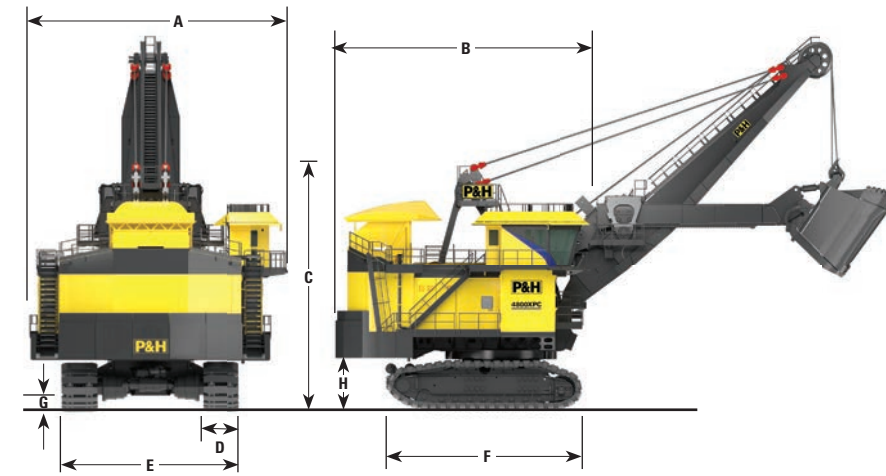

Overall dimensions			
A Width	15.0 m	49 ft. 3 in.	
B Length	15.2 m	50 ft. 0 in.	
C Height over gantry	14.7 m	48 ft. 2 in.	
D Width of crawler shoes	2540 mm	100 in.	
E Width of crawlers (100")	11.1 m	36 ft. 5 in.	
F Length of crawlers	11.5 m	37 ft. 8 in.	
G Ground clearance	0.7 m	2 ft. 2 in.	
H Height — ground to bottom of counterweight slabs	3.3 m	10 ft. 9 in.	

Power requirements			
Supply voltage*	7200 or 13800V 3 phase, 60 Hz	6000, 6600, 7200 or 11000 3 phase, 50 Hz	
Supply transformer	(minimum) 3750 kVA		
Minimum short circuit VA available at shovel	30 MVA		

\*Voltage per customer requirements

- | Adaptive controls technology                          |  |
|---|--|
| • Smart control and application of power              |  |
| • Improves shovel production without sacrificing life |  |
| • Reduces boom jacking                                |  |

- | Swing  |  |
|--|--|
| Three modular P&H planetary gear cases of proven design and a single piece forged swing gear transmit torque for fast cycle times. |  |
| Spring-set air release disc brakes — one per motor.  |  |
| Splash lube filtration system.   |  |

- | Propel  |  |
|---|--|
| Propel on demand provides rapid transfer to propel mode. Rapid transfers allow frequent positioning of the shovel to the bank resulting in faster cycle times and more efficient digging. |  |

- | Crowd  |  |
|--|--|
| Two rugged P&H planetary gear cases of proven design independently transmit torque to the drive sprockets, producing the tractive effort required for fast, efficient propel and positioning operations. |  |
| P&H Delta drive low tension sprocket drive system with heavy duty cast crawler shoes.  |  |
| Spring-set air release disc brakes — one per motor.  |  |

- | Hoist  |  |
|--|--|
| Twin low inertia AC motors minimize shock loading and boom jacking.                  |  |
| Direct drive crowd eliminates belt maintenance for improved responsiveness.          |  |
| Modular crowd motors with integral pinions provide for simplified motor replacement. |  |
| Two input pinions share load for extended life.                                      |  |
| Dual spring-set air release brakes for reliable redundant operation.                 |  |

- | Hoist  |  |
|--|--|
| All gearing housed in single enclosed gear case with filtered and cooled oil fed to all bearings in addition to splash lubrication for reliable operation and ease of maintenance. |  |
| Large 68" diameter hoist drum for extended rope bending life. Ferrule becket system and dual electric tuggers are standard for efficient rope change.                              |  |
| Spring-set air release disc brakes — one per motor.  |  |
| Hoist rope fleeting sheave protects rope from excessive oscillation.   |  |



Through the application of innovative engineering and advanced technologies, Komatsu has designed the 4800XPC to be the industry's most productive electric mining shovel.

Contact a Komatsu Mining service representative for more information on the P&H 4800XPC or visit <https://mining.komatsu>

## Komatsu Mining Corp. Group

mining.komatsu



Product designs, specifications and/or data in this document are provided for informational purposes only and are not warranties of any kind. Product designs and/or specifications may be changed at any time without notice. The only warranties that apply to sales of products and services are Komatsu's standard written warranties, which will be furnished upon request.

Komatsu, Joy, Montabert, P&H, Delta and other trademarks and service marks used herein are the property of Komatsu Ltd., Komatsu Mining Corp., or their respective owners or licensees.

© 2019 Komatsu Mining Corp. All rights reserved.